

PLOW BOLTS (GRADE 5 AND 8)

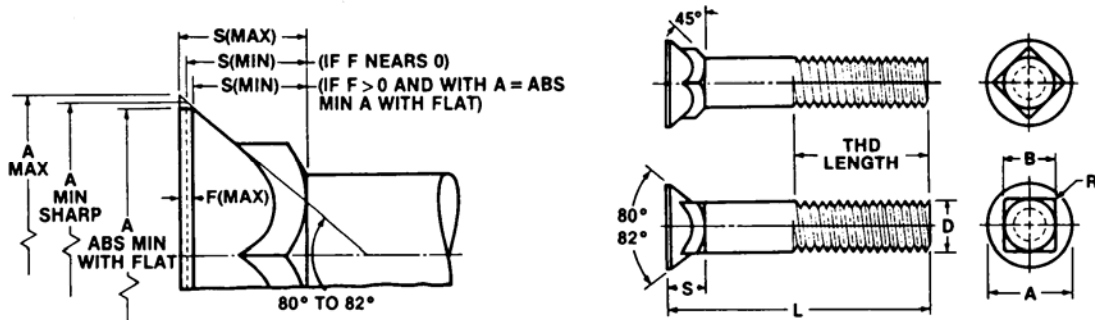

Basic Diameter	A			F	S		B		R ¹
	Diameter of Head			Feed Thick.	Depth of Square and Head		Width of Square		Radius on Corners of Square
	Max	Sharp	Flat Min	Max	Max	Min	Max	Basic Min	Max
5/16	.605	.578	.563	.025	.269	.243	.325	.313	1/32
3/8	.708	.671	.656	.031	.312	.281	.387	.375	3/64
7/16	.826	.781	.766	.036	.364	.328	.450	.438	3/64
1/2	.945	.890	.875	.042	.417	.375	.515	.500	3/64
9/16	1.045	1.000	.969	.045	.461	.416	.578	.563	5/64
5/8	1.147	1.094	1.063	.050	.506	.456	.640	.625	5/64
3/4	1.303	1.250	1.219	.050	.541	.491	.765	.750	5/64
7/8	1.512	1.469	1.406	.063	.626	.563	.906	.875	3/32
1	1.700	1.656	1.594	.063	.690	.627	1.031	1.000	3/32

ASME B18.9

