

METRIC FLAT HEAD PHILLIPS MACHINE SCREWS

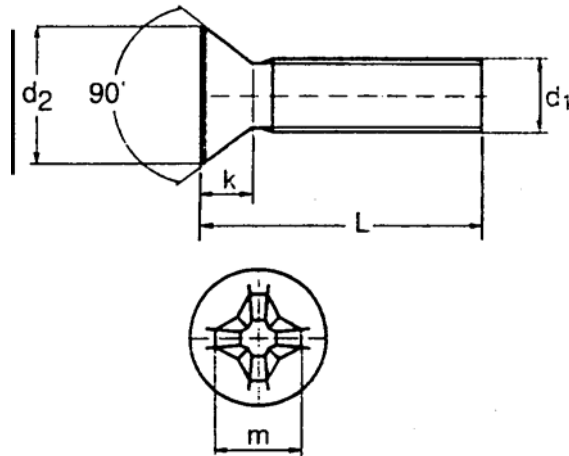

Diameter	d_2	k	m
	Head Diameter	Head Height	Recess Diameter
M2	3.8	1.20	2.35
M2.5	4.7	1.50	2.70
M3	5.6	1.65	2.90
M4	7.5	2.20	4.40
M5	9.2	2.50	4.60
M6	11.0	3.00	6.60
M8	14.5	4.00	8.70
M10	18.0	5.00	9.60